

QDX PUSH-PULL

PUSH-PULL SYSTEM FOR QUICK DIE XCHANGE

press-mounted or mobile die loader with
original rigid-chain technology

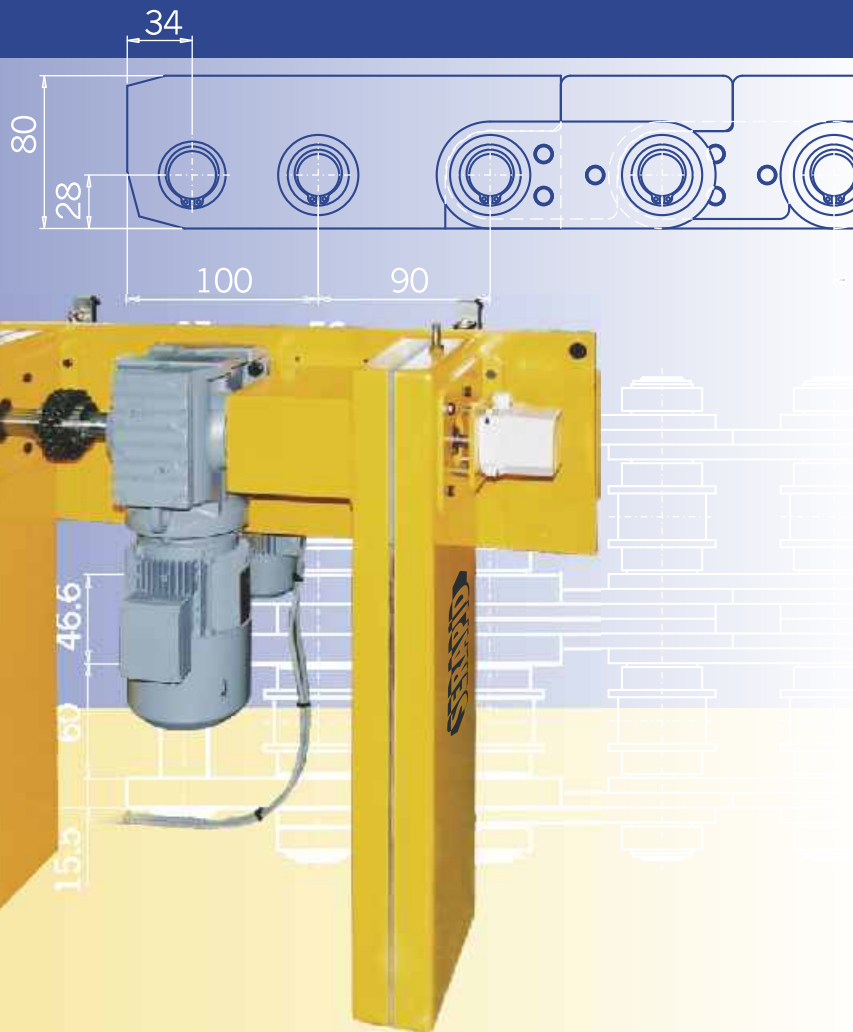
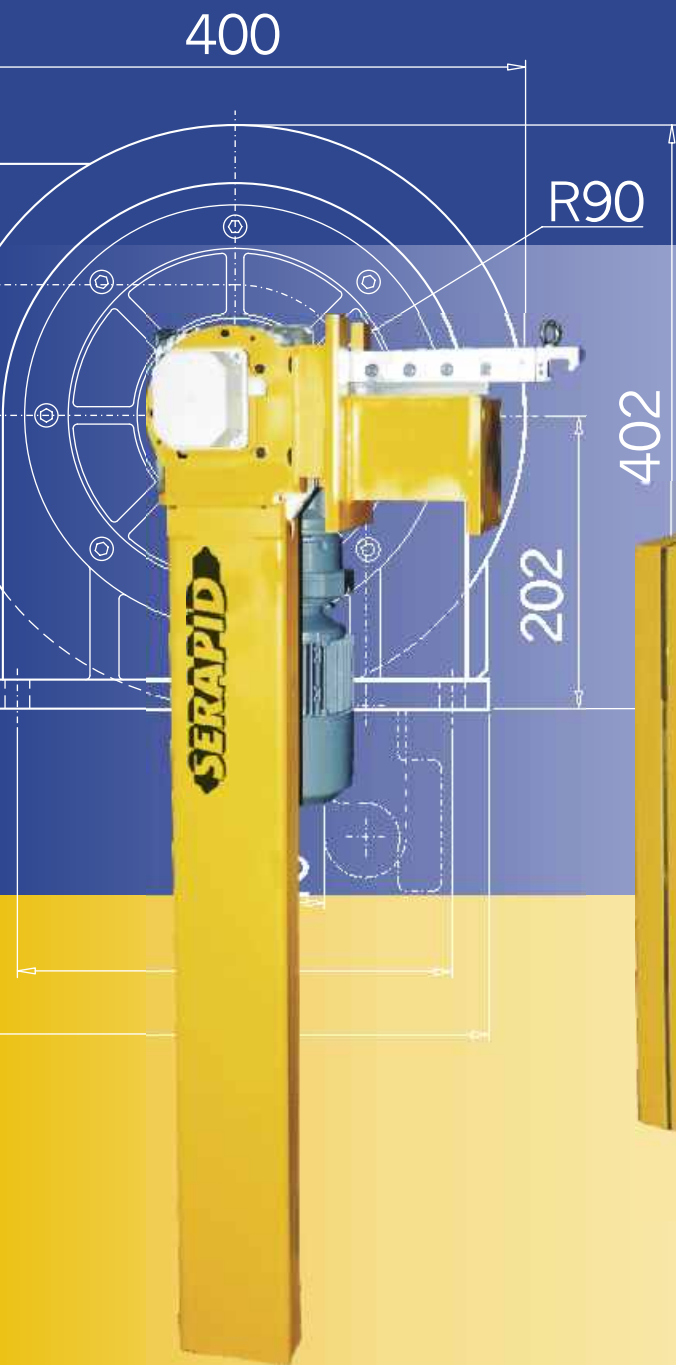

SERAPID

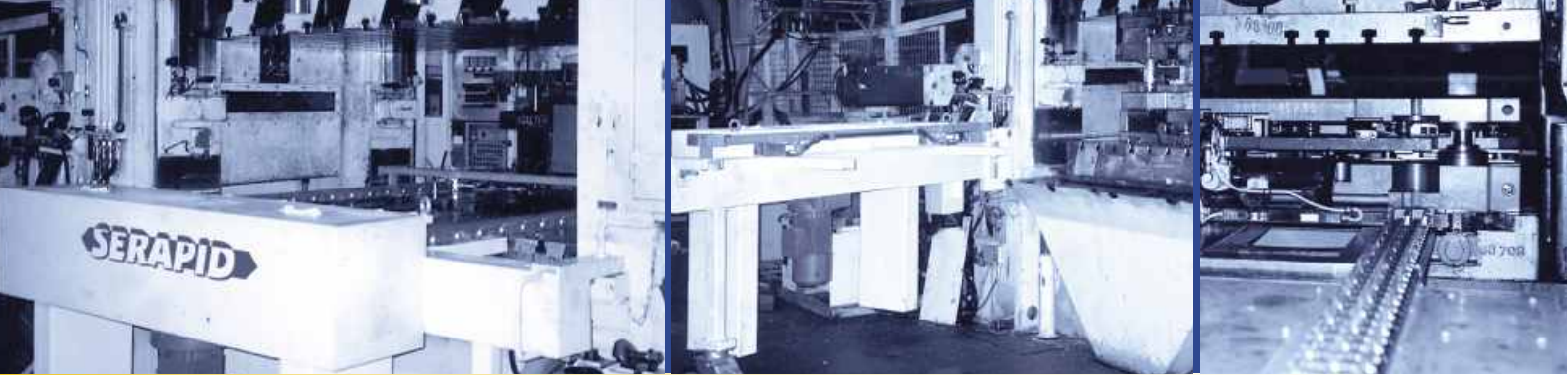

For the hard work in Quick Die Xchange

A QDX Push-Pull System from SERAPID, easily attached to your existing press equipment, lets you handle dies safely, ergonomically and efficiently.

When setting up a press, the handling of dies inside the machine certainly is one of the hardest jobs. And it can get time-consuming and safety-critical, too.

Let a SERAPID **QDX Push-Pull System** do it. Move and position dies safely, accurately and efficiently. Without manual intervention in potentially dangerous machine zones. Easily controlled by one operator from a remote panel. In a defined, repeatable way, without having to re-adjust the die. And with care, saving the die itself from accidental damage, too.

attaching it to the press

The QDX Push-Pull System is simply mounted to the **back or side of your existing press**. As an option, it can be fitted with a swivel mechanism or be mounted on a cart, so it can be docked on or off as required.

what it does

The system's built-in **rigid chains** pick up the die from a defined loading position and **pull** it exactly into operating position. In the other direction, the chains **push** the die back out of the press slot.

how it works

All operations are **controlled via sensors and switches**. This ensures that the movement of several tons of costly equipment is only performed in proper sequence and under safe conditions. For example, the operator can trigger the chain drive only when the press has come to a halt and clamps have been opened.

The standard Push-Pull-System comes ready for **full electric control**.

SERAPID

QDX PUSH-PULL

A Push-Pull System from SERAPID will contribute essentially to press-room **ergonomics and safety**. It will make your die changing process fully compliant with relevant standards and regulations.

how it integrates into your workflow

The Push-Pull System can be combined with existing staging tables and consoles, as well as with roller bars, die lifters and clamps. If required, we are ready to supply a **wide range of die-handling accessories** as components of the system.

Thanks to SERAPID's rigid-chain technology, the QDX Push-Pull System takes **minimum space** and can be installed easily in most environments.

system components

A standard QDX Push-Pull system consists of **one or two chain drives** powered by an electric gear motor, a pushing bar with semi-automatic hooks and a mounting bracket to the press. In addition, the system standardly includes a cam switch to limit the stroke and control positioning movements.

Several configuration options allow you to adapt the system to existing conditions of space and to integrate it into your production line.

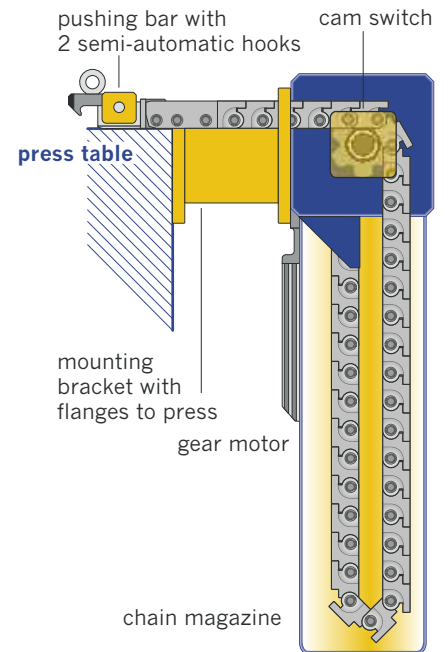

the SERAPID chain

The rigid pushing chain is an original SERAPID product and is proven the superior solution in a wide variety of linear motion tasks. It is basically a chain with special links. This link features a hook-like extension, which we call the shoulder. The shoulder serves as a joint between

neighbouring links. When force is applied, the shoulders interlock and make the chain as rigid as a jack. At their cross-axes, the links are connected flexibly, just as in an ordinary chain. Thus, the rigid chain will still bend and can be coiled up and stored very efficiently.

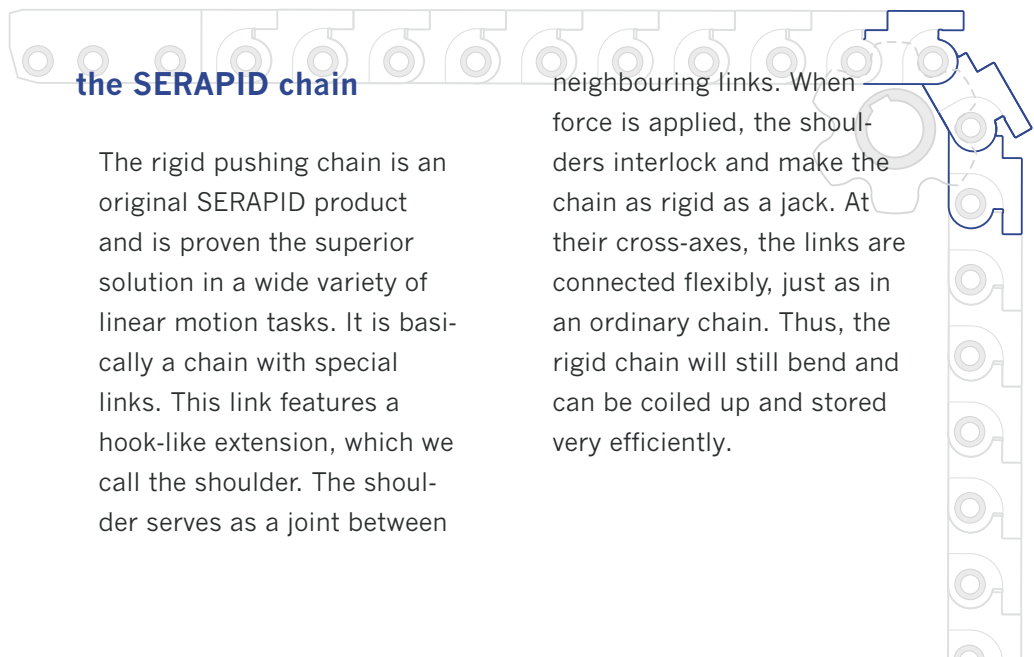

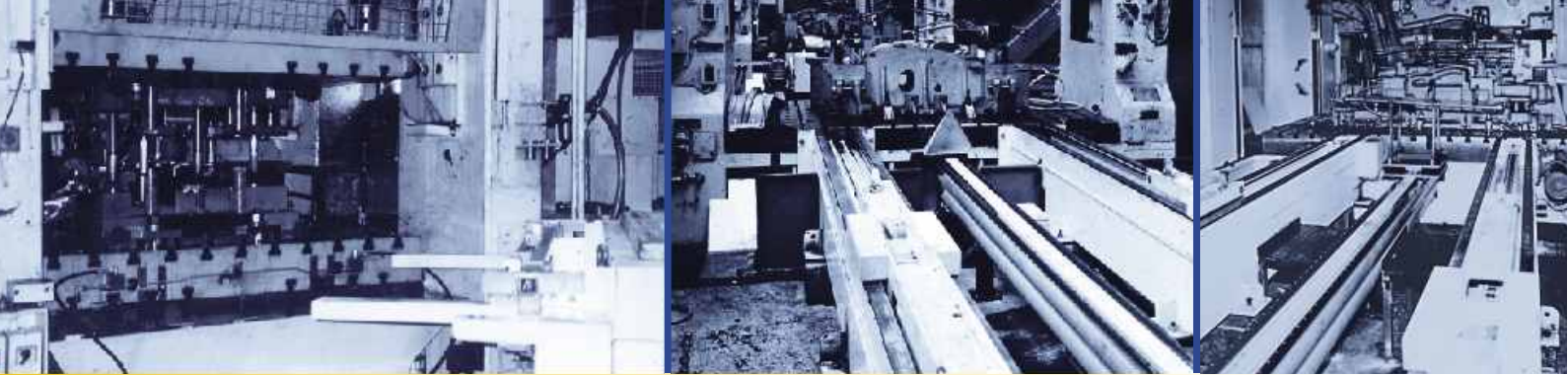

Types and configurations

basic configurations

Depending on the size and weight of the die, the QDX Push-Pull System may comprise one or two rigid chains. With a single chain, the die has to be guided. With dual chains, this is not necessary.

When only one chain can be used, it may be guided to improve stability and capacity. In such cases, the chain guide can be used to guide the die as well. Ask SERAPID Engineering for details.

storage options

The chain magazine is available with two or three return strands, depending on stroke length and/or mounting height. If the stroke is long and/or the press bed is

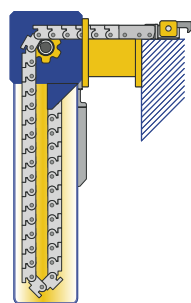

magazine with 2 strands

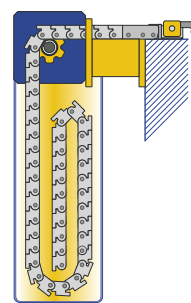

magazine with 3 strands

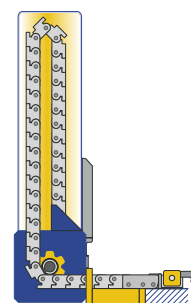

chain magazine in upward orientation

low, a magazine with three return strands may be required. Conversely, if the stroke is short and/or the press bed is high, a magazine with only two strands may suffice.

The magazines are normally installed downwards, below the operating level. If required, they can also be installed in upward orientation. In this case the chains operate with their shoulders down, so the locking parts receive additional support from the worktop. This makes it easier for the chain to bridge gaps in the transfer path.

types and capacities

SERAPID offers two types of the QDX Push-Pull System, the **PPS 40** and the **PPS 60**.

PPS 40-1, single chain:

- up to **5 000 N** total applicable force
- suitable for dies up to **4 tons**, sliding metal on metal / up to **8 tons** on rollers

PPS 40-2, dual chains:

- up to **10 000 N** total applicable force
- suitable for dies up to **8 tons**, sliding metal on metal / up to **16 tons** on rollers

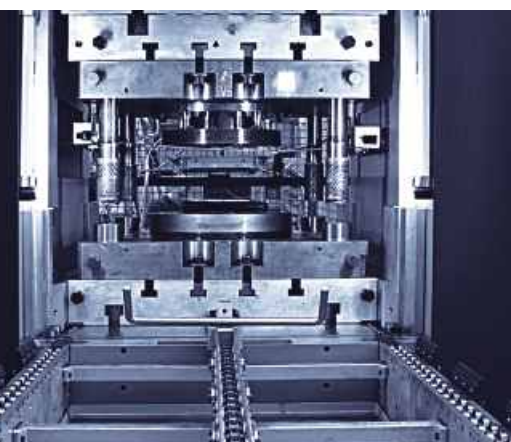

QDX PUSH-PULL

PPS 60-1, single chain:

- up to **17500 N** total applicable force
- suitable for dies up to **8 tons**, sliding metal on metal / up to **16 tons** on rollers

PPS 60-2, dual chains:

- up to **35000 N** total applicable force
- suitable for dies up to **16 tons**, sliding metal on metal / up to **32 tons** on rollers

Motion speed is up to 150 mm/sec with all our Push-Pull Systems. For speeds above 80 mm/sec a frequency drive should be used to keep dynamic loads low.

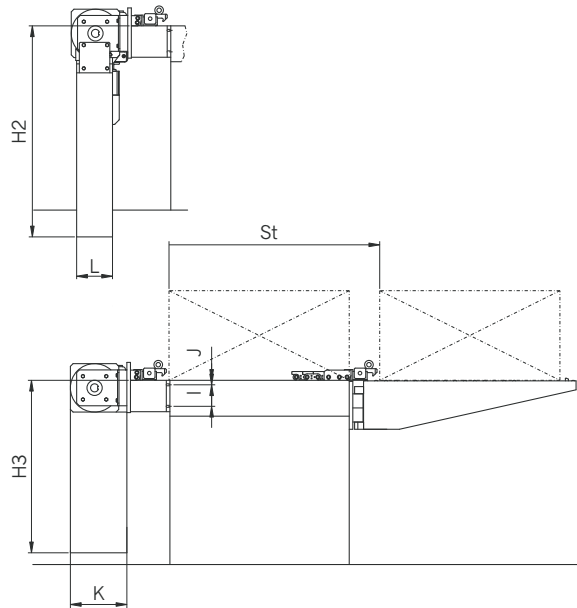

standard stroke lengths and magazine heights

std stroke St	PPS 40		PPS 60	
	H2	H3	H2	H3
1200	869	547	–	–
1400	969	614	1077	668
1600	1069	681	1177	735
1800	1169	747	1277	802
2000	1269	814	1377	868
2200	1369	881	1477	935
2400	1469	947	1577	1002

H2 = height of magazine with 2 return strands (free)

H3 = height of magazine with 3 return strands (guided)

Choose according to mounting height (level of press bed) and/or length of stroke.

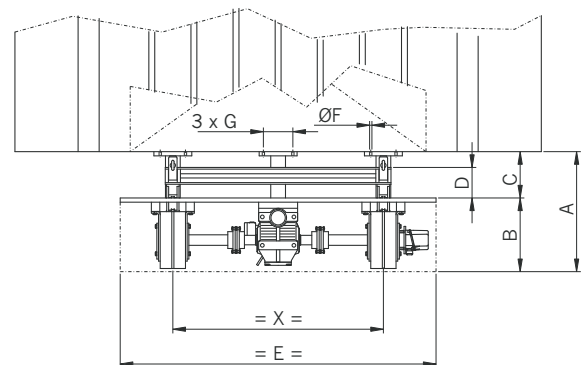
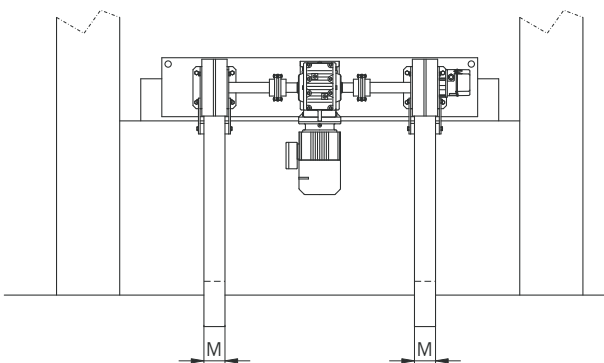

dimensions

PPS type	A	B	C	D	E	F	G	I	J	K	L	M	X min
PPS 40	460	290	170	95	1200	12 Ø 11	100	100	30	271	140	100	660
PPS 60	600	400	200	120	1460	12 Ø 11	120	120	40	330	200	120	900

All dimensions in mm.



Options

Several options are available for the Push-Pull System, including special designs and automation elements.

design possibilities

Upward oriented chain magazine: used if there is no sufficient space under the press level.

Gear motor in custom position: motor with shaft extensions mounted on either side of system or below press level.

Extended stroke length and extra capacity: consult SERAPID Engineering for non-standard requirements.

attaching the die

Automatic hooks: A hydraulic, pneumatic or purely mechanical hooking device allows coupling and uncoupling of the die without manual action. This is particularly useful when the target position of the die inside the press is inaccessible to operators.



Interfacing loops: The loops are attached to the die, to engage with the hooks on the Push-Pull System.



drive and control

Hydraulic chain drive: alternative to electric gear-motor drive.

Electric torque limiter / current monitor: halts movement on hitting a mechanical stop or obstacle.

Electric control module: all system operations can be defined, and operating states can be queried, thus allowing full automation of loading procedures. Also available with frequency drive.



QDX PUSH-PULL

removable and mobile Push-Pull Systems

System mounted on swivel mechanism: This option allows you to dock the die loader on when required and swing it aside when no longer needed. During operation of the press, the space can thus be used for parts conveyors or other purposes.

System mounted on roller cart: The roller cart is height-adjustable, thus allowing you to use the system on different presses. A quick fixation mechanism docks the cart securely with the press.



System integrated into bolster extension: The Push-Pull system is combined with a loading console that includes two bolster extensions. The die console is height-adjustable. Integrated docking and fixation devices secure it in its operating position. The supporting structure can be welded onto a pallet jack. Alternatively, the system can be moved with a standard fork-lift cart.

further QDX equipment

Together with our partner company, LJC, we are able to offer a full range of clamping equipment, as well as die lifters, rollers and bolster extensions.

Get everything it takes from one, competent supplier.



QDX PUSH-PULL

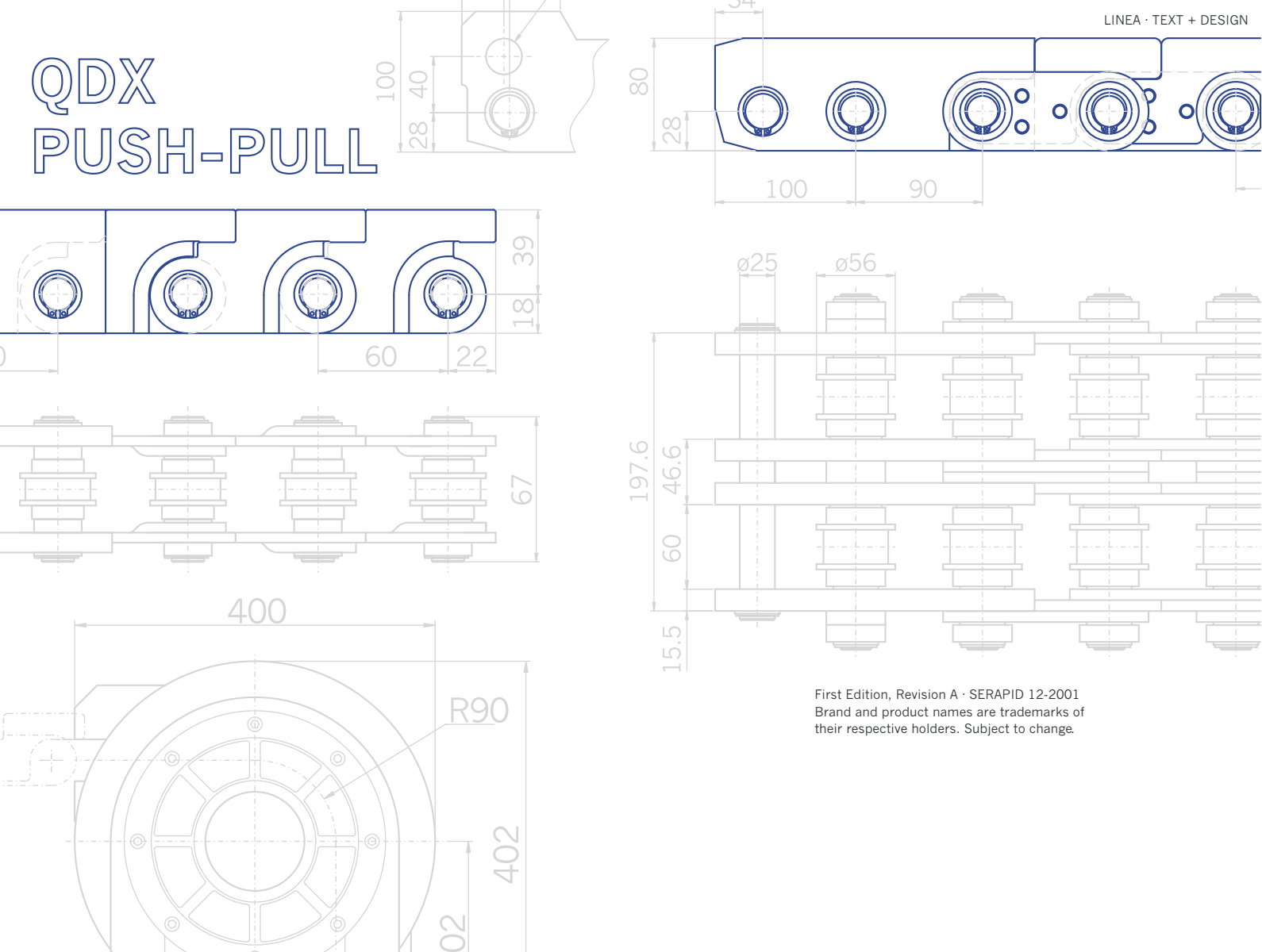

First Edition, Revision A · SERAPID 12-2001
Brand and product names are trademarks of
their respective holders. Subject to change.

SERAPID representative



SERAPID
PUSHING AHEAD

www.serapid.com

France · United Kingdom · Germany · Austria · Switzerland · Belgium ·
Luxembourg · Spain · Italy · The Netherlands · Denmark ·
Sweden · Finland · Norway · USA · Japan

SERAPID UK

5 Brentwood Close, Littleborough
Lancashire OL 15 0ND, UK

Phone +44 (0)170 637 62 30

Fax +44 (0)170 637 10 29

info-uk@serapid.com

SERAPID S.A.

453, Route de Dieppe · B.P. 15
F-76660 Londinières

Tél. +33 (0)2 35 93 82 82

Fax +33 (0)2 35 94 10 93

info-fr@serapid.com

SERAPID Deutschland GmbH

Postfach 1711
D-97967 Bad Mergentheim

Tel. +49 (0)7931 47 77 05

Fax +49 (0)7931 47 77 11

info-de@serapid.com

SERAPID USA INC.

6600 Sims Drive
Sterling Heights MI 48313, USA

Phone +1 586 274 0774

Fax +1 586 274 0775

info-us@serapid.com

