

SERAPID
RIGID CHAIN TECHNOLOGY

PRESS EQUIPMENT FOR QUICK DIE CHANGE

QUICK DIE XCHANGE
QDX

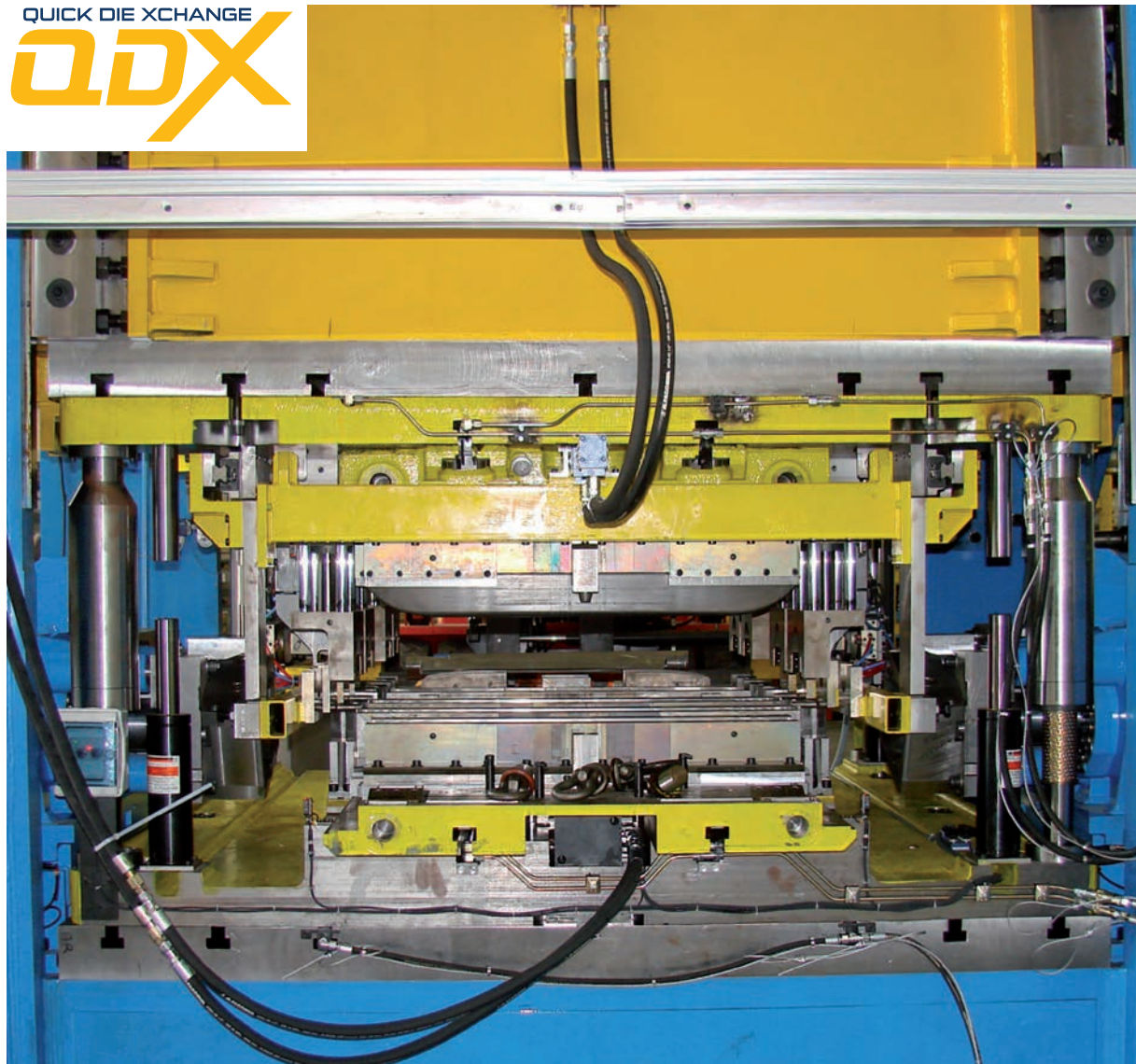

THE COMPLETE PROGRAM FOR QUICK DIE CHANGE: CLAMPING AND POSITIONING

Production variety and just-in-time manufacturing make die change a critical factor for the entire press operation. Smaller production runs can be less efficient, as more frequent retooling increases downtime. Frequent change also increases both the risk of operator injury and damage to the tools.

With the QDX program, you will improve your performance by drastically reducing downtime and increasing the overall efficiency of your equipment.

Efficient, reliable and low maintenance

The QDX covers the entire process of die change. Components are optimised for results that really count to make the process of die change quick, smooth and efficient.



Quick and safe press tool clamping system



Press tool positioning system

Clamping

We offer a variety of clamps for both standard and exceptional working environments. Clamping and unclamping of dies is automatic or with minimal manual intervention.

Positioning

Our die rollers and lifters let dies glide smoothly into their clamping positions. Our motion systems drive them safely and accurately on pre-defined transfer paths.

Transporting

Our transporters range from GPO truck to rail-bound die shuttles that will take your dies to the press and back to storage, reducing transit and handling time.

Safety, ergonomics and efficiency

The best die change system will be the one that meets these three goals :

Safety

With a QDX System, no human operators need enter or reach into hazardous areas. Control and locking mechanisms effectively prevent any dangerous human contact. Less operator contact means less opportunity for error, and a safer manufacturing environment overall.

Ergonomics

The heavy outgoing and incoming dies are moved by machines on pre-defined tracks with operators controlling the process from remote panels. Depending on the amount of automation implemented, manual actions can be reduced to a minimum.



Clamping and unclamping tools on a press table with ease and safety



Quick change of fluid and secure tools

Efficiency

A QDX system will reduce die change times to a few minutes. That is a figure you can count on, since the system standardises the change process. Moreover, your equipment will be handled smoothly and carefully, and be protected against damage and wear.

The SERAPID QDX die change system meets these goals in each of the three phases of the change process: clamping, positioning and transporting.

To each his own - all from a one-stop shop

Die change is a complex process requiring experience in many fields. Clamping, rolling and motion technology are closely related, but encompass a broad range of engineering and manufacturing disciplines. Although SERAPID keeps dedicated manufacturing sites for specific types of projects, our specialised teams work together closely and maintain a constant dialogue of information and experience. For our customers, this brings many benefits, whether you are interested in specific die change components, or a complete system. We are happy to provide you with a standard or a custom-designed solution.



BUILDING YOUR QDX SYSTEM STEP BY STEP

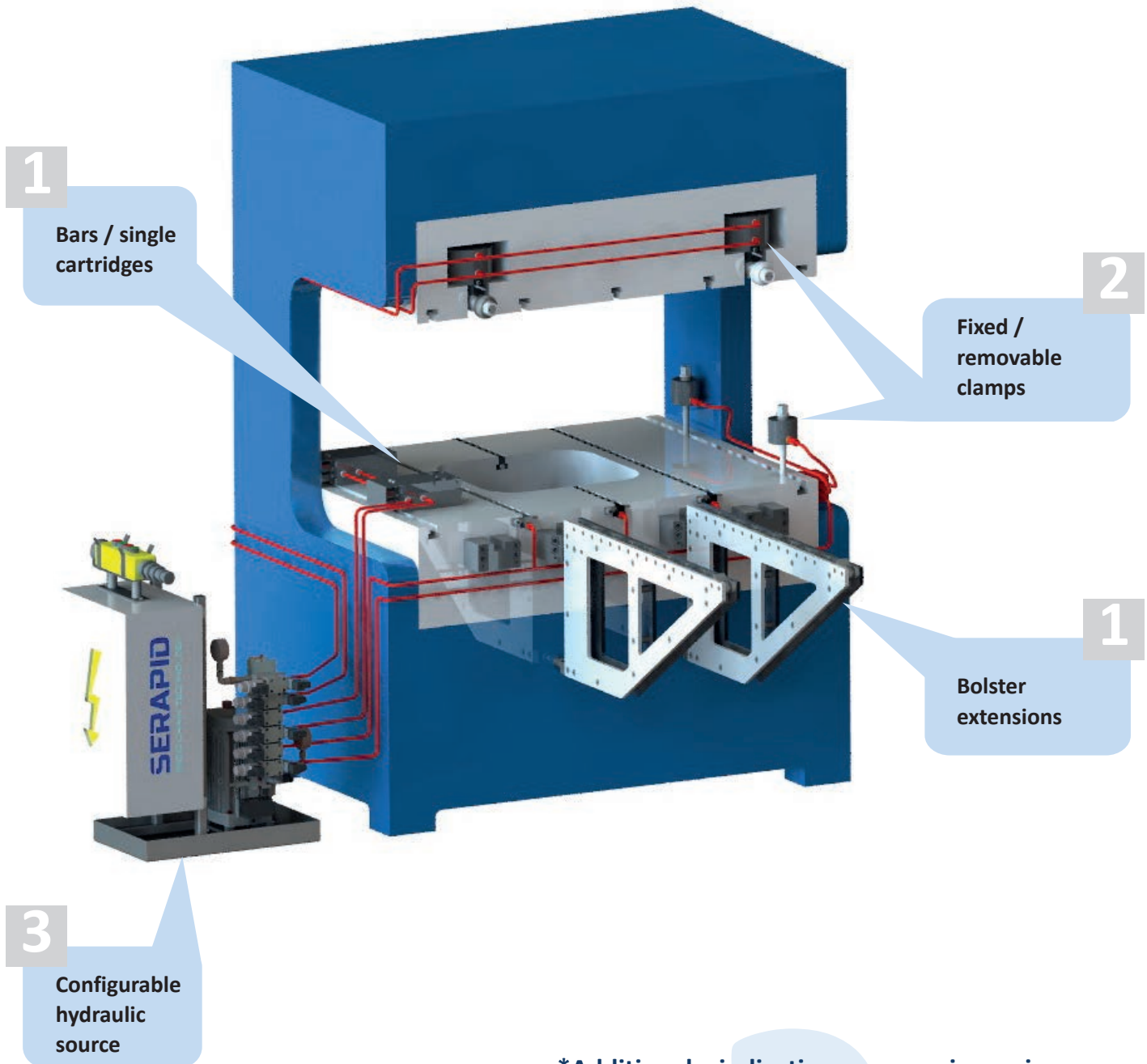

***Additional indications are given in parentheses in the product titles.**

They refer to the data sheets of these products that you can find in the "Documentation" section of our website www.serapid.com.

Example :

→ BTSC (040-07*)

"040-07" is the SERAPID reference of the corresponding data sheet.

Single cartridges

Bars

Bolster extensions

1

Tracks and running surfaces are the basis for simple transfers and precise positioning of the tool.

Step 1

p. 6 - 11

Balls / rollers / rollers on bearings

Single cartridges / bars

Hydraulic / mechanical lifting

Bolster extensions / bars with fixed rollers

LGHL (010-05*)

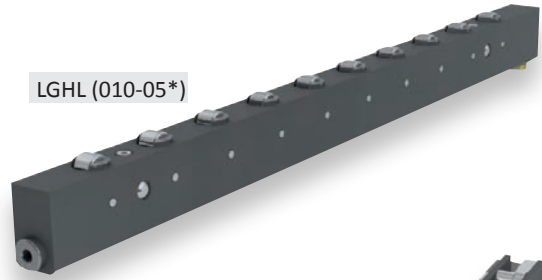

Bolster extension CSL (100-01*)

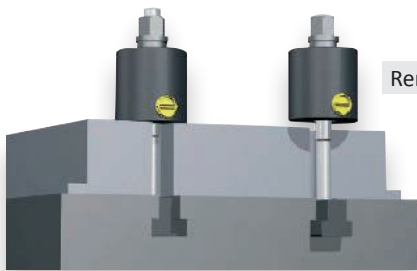
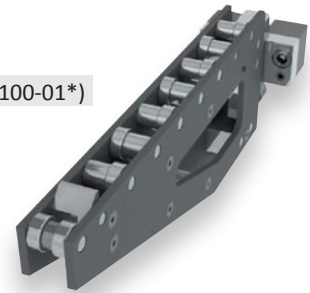

Removable clamp BTSC (040-07*)

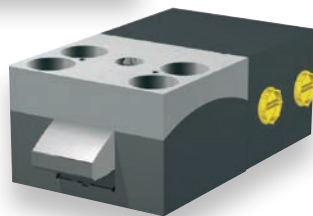

Fixed clamp TBHS (080-03*)

Clamps

2

We offer a comprehensive selection to choose from: fully automated or manually supported clamps

Step 2

p. 12- 19

Fixed / removable clamps

Embedded / retractable clamps

Roller-bar clamps

Rod clamps

C-clamps

Lever clamps

Hydraulics

3

Rollers and clamps typically require a hydraulic power source. We supply equipment suitable for your system, from the simple manual pump to the electrically controlled power pack.

Step 3

p. 20 - 21

Manual pump / air-driven pump

Air-driven / electric power pack

Accessories

Full installations

Compact electric unit with connection terminal box (110-04*)

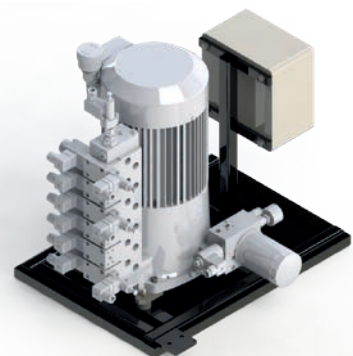

1 SINGLE CARTRIDGES, BARS, BOLSTER EXTENSIONS

Single cartridges and bars (range p. 8 - 9)

Rolling elements integrated into bolsters and feeding devices make smooth pathways for quick die change. Considering the size and weight of the die as well as economic and application-dependent aspects, there are different ways to implement efficient rolling.

Rolling on balls

Allows flexible and highly accurate positioning. The die can be moved in any direction and at any angle. This is useful for smaller dies that are positioned manually (< 2 t).

Rolling on cylindrical rollers

Allows only forward and backward movements. Positioning accuracy is ensured by using guides and/or a loading device, such as our Push-Pull System (PPS). The load capacity is much higher (> 2 t).



Rolling on roller bearings

Is possible with some of our roller bars, which can also be furnished with antifriction bearings for an even lower rolling effort. These bearings are also available in waterproof and dustproof treatments. A SERAPID Push-Pull System, is strongly recommended.

LGGR (020-04*)



For further information on our rolling elements and bolster extensions, visit our website www.serapid.com. To find or request datasheets and technical drawings, use the code specified with each product, for instance:

→ BTSC (040-07*)

When are rolling elements required?

Always. Although it is possible in some cases for the die to simply slide across the bolster (steel / steel), more frequent die changes require a smoother running system.

Damage to the bolster and die, time lost with difficulty in positioning dies, higher energy consumption are all factors that can cut down on profitability. Rolling elements, by contrast, ensure optimal operation at one-time-only cost.

Tools > 2 t

Rolling elements should be used for any tool over 2 tons.

Tools > 10 t

For dies above 10 tons, heavy-duty bars, in special slots, should be used. If this is not possible, fixed rollers should be installed on the loading console or staging table outside the press to minimise the risk of shocks.



Quick Die Change system using rolling ramps

SELECTING ROLLING ELEMENTS

■ Mechanical or hydraulic?

Balls and rollers are lifted either mechanically or hydraulically. Springs press the rolling element against the die permanently, even when it is clamped down. Hydraulically lifted rolling elements, in contrast, retract to their resting positions when the pressure is released.

■ Single cartridges or bars?

Our rolling elements are available in bars that fit into standard or special slots in the press bolster, or in separate cartridges that can be installed in any desired arrangement.

Bolster extensions (range p. 10 -11)

Bolster extensions

These are used for positioning the die in front of the press or to bridge gaps between the bolster and a die cart. They are used to fill the gap between the press and the rail-mounted carts or shuttles. Our bolster extensions are equipped with large rollers so that the tool rolls smoothly and without shock. Rolling bolster extensions are compatible with bars and T-slots (DIN 650).

■ Size of the T-slots?

Our rolling bars are available in DIN 650 sizes from 18 to 36. To be safe, always check the true dimensions of the T-slots in the press bolster. Specific manufacture on request.

■ Hydraulic feed?

Horizontal or vertical with $G^{1/8}$ ", $G^{1/4}$ " (BSPP) or UNF $7/16$ ", UNF $9/16$ ". Specific manufacture on request.

■ Lifting force?

The total force required to lift the die is spread over rolling elements. Consider the distance between rolling elements as well as any gaps in the bolster. For instructions on calculating the load see our datasheet 010-00*.

■ Dynamic load?

Check the relevant graphs provided in the datasheet 010-00* to make sure the dynamic capacity of the rolling elements will not be exceeded. Dynamic overload will damage the contacting surface. If necessary, reinforce the rolling path with hardened steel strips.

■ Rolling friction?

Using balls the rolling friction depends chiefly on the hardness of the surface. Friction coefficient between 0,15 and 0,2. With small rollers ($\varnothing < 30$ mm), the friction coefficient typically lies 0,07.

In general, for a entered load, the bigger the rollers are, the lower the friction is.

→ 100-07* **Extension options**

1 Single cartridges and bars

- Various dimensions and capacities
- Custom manufacturing, adapted to your standard DIN 650 or special slots
- Standard working temperature up to 70 °C, 160 °C with Viton seals

Balls	Hydraulic
Multi-directional movements Low rolling resistance with a coefficient of 0.15 up to 0.2	100 bars G ¹ / ₈ (BSPP) or UNF 7/ ₁₆ connections
Rollers	Mechanical
Single-direction movements Very low rolling resistance with a coefficient of 0.07	Spring washers "Belleville"

Ball bars LBR / LBH

- Can be combined in lines
- Especially suitable for manual die positioning
- When the die is clamped, the ball retract (LBR)
- Mechanical lifting with spring washers "Belleville" (LBR) and hydraulic (LBH)
- When the die is clamped, the bar exerts no effort on the sole; return by gravity (LBH)
- Available for your slots according to DIN 650 T 18, 22, 24, 28 and 36 (LBH)

Balls

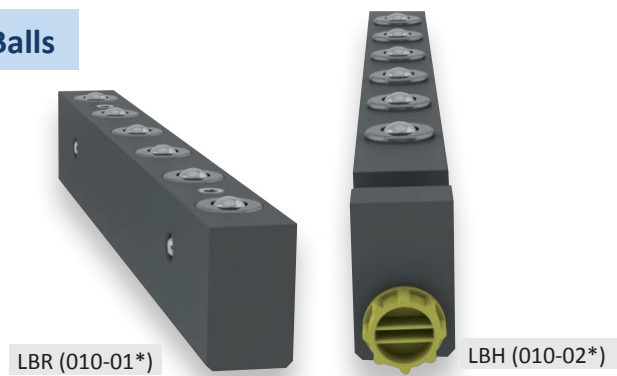

Rollers

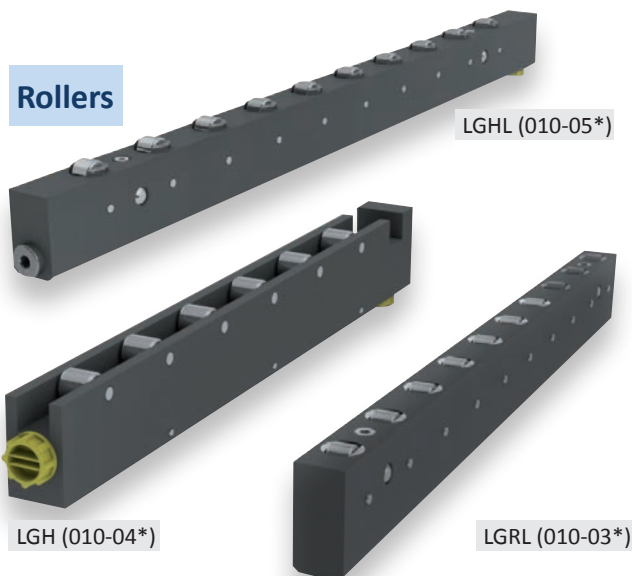

Roller bars LGRL / LGH / LGHL

- Can be combined in lines
- Hydraulic lifting for LGH & LGHL and mechanical lifting with spring washers "Belleville" LGRL
- High dynamic capacity (LGH)
- When the die is clamped, the rollers retract (LGRL)
- When the die is clamped, the bar exerts no force on the sole (LGH & LGHL)
- Available for your slots according to DIN 650, sizes 22 up to 36 for LGRL & LGHL and 18 up to 36 for the roller LGH

Retractable ball cartridges LC

- Used to create rolling surfaces of different sizes and shapes
- Built into the bolster, can be used when there is no available slot
- Adapted housing machined into the bolster or the sole of the die
- With spring washers "Belleville"

Balls



LC (030-01*)

Rollers



CG / CGX (030-02*)

CGH (030-03*)

Retractable roller cartridges CG / CGX / CGH

- Used to create rolling surfaces of different sizes and shapes
- Built into the bolster, can be used when there is no available slot
- Adapted housing machined into the bolster or the sole of the die
- With spring washers "Belleville" (CG / CGX)
- Hydraulic piston lifting (CGH)
- Various dimensions and capacities

Standard or heavy load static roller bars LG / LGG / LGGR

- Bars with static rollers (no lifting mechanism)
- Use as a track for heavy dies (LG) and very heavy dies (LGG et LGGR) outside the press for the use in the die loading or storage systems
- Recommended for dies weighing > 10 t (LGG et LGGR)
- Adding of a lateral guidance version LGGL (020-07*)

Rollers

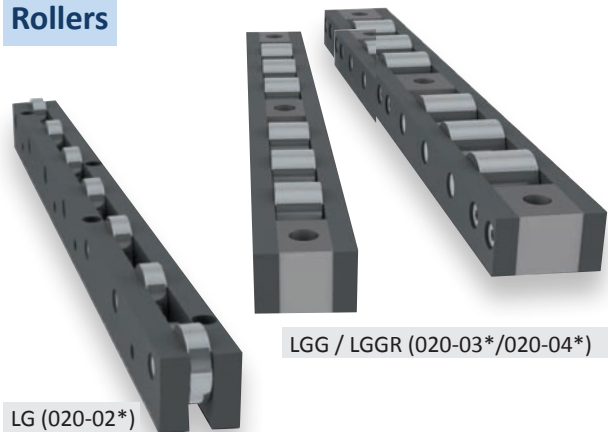

LG (020-02*)

LGG / LGGR (020-03*/020-04*)

Rollers

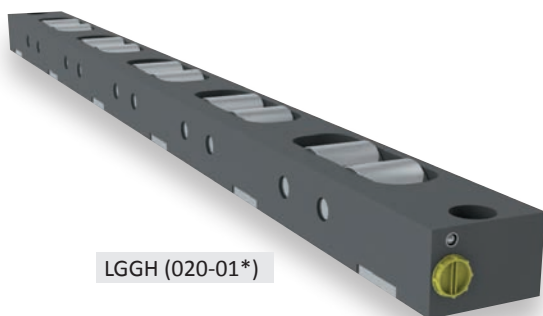

LGGH (020-01*)

Heavy load hydraulic bar LGGH

- Hydraulic lifting
- Can be mounted upside down with the rollers towards the bottom, on the outgoing bolster
- Recommended for dies weighing > 10 t
- LPGH version for 50 x 50 mm slot (020-05*)
- G¹/₄" (BSPP) or UNF ⁹/₁₆

1 Bolster extensions



CSL (100-01*)

Specifications

- Screwed construction with mainly aluminium bolster sides
- Hardened steel rollers on friction pads
- Retractable stopper provides a fall safety mechanism for the die
- Especially adapted for manual die positioning
- Manufactured to order with special dimensions

Removable bolster extension CSL

- Extension positioned manually
- Horizontal and vertical adjustment



CSP (100-02*)

Removable bolster extension with leg CSP

- Extension positioned manually
- Optional additional cross pieces and legs to create a loading table (on request)
- Optional wheeled leg (see sheet 100-07)

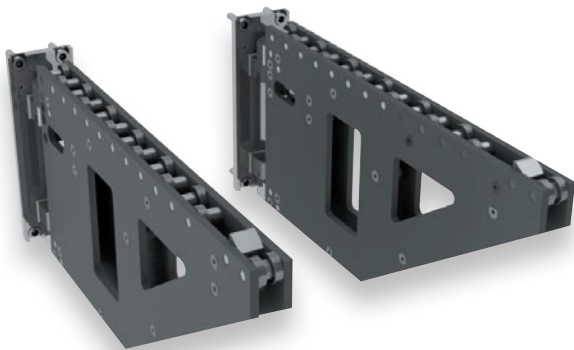

CSM (100-03*)

Removable swing-aside bolster extension CSM

- Open / closed position locked

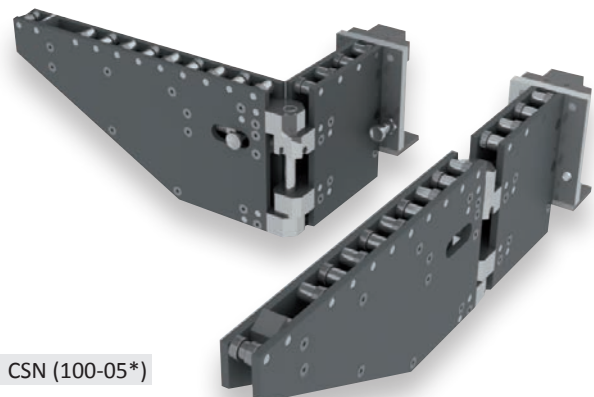

CSN (100-05*)

Swing aside double pivot extension CSN

- Open / closed position locked

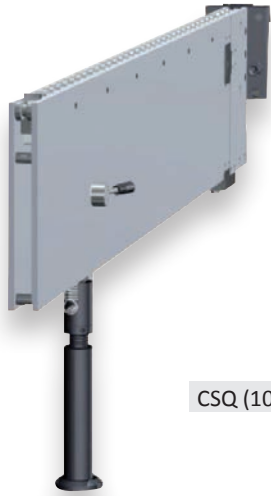

CSQ (100-04*)

Removable swing aside bolster extension with leg CSQ

- Open / closed position locked
- Optional wheeled leg (see sheet 100-07)

Swing aside, double pivot extension with leg CSR

- Double pivot, especially designed for small swing aside space
- Open / closed position locked
- Optional wheeled leg (see sheet 100-07)

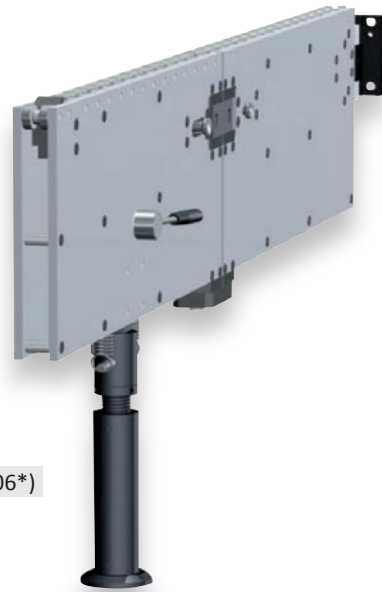

CSR (100-06*)

Extension mounting configurations CSM & CSQ models

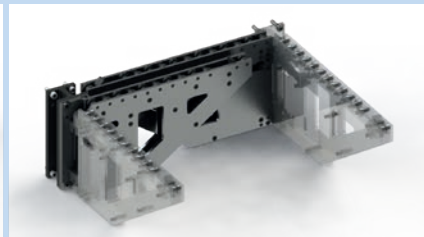
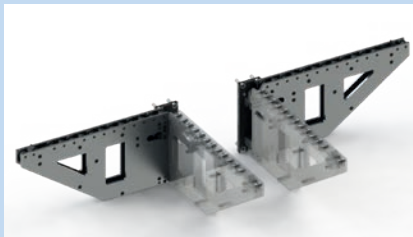

Extension options



for all extensions



for CSP extension

2 CLAMPS

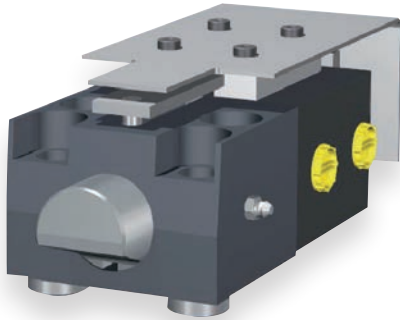

Fixed clamp TBH (080-01*)

The essential qualities of a clamp are the speed of opening and closing, and the ease of inserting and removing. Our comprehensive range of clamps will offer the best solution for your application.

The clamping force

It should at least be equal to the opening force of the ram - approximately 10% of the striking force in common applications. The clamping force is the same on bolster and ram. Divide this force by the number of clamps to be used on either part, bolster or ram, to obtain the capacity of each clamp.

For large and heavy dies, and for high strike rates (above 200 per minute), consider the relevant amount of inertia on moving the ram. For this, please contact our technical support.

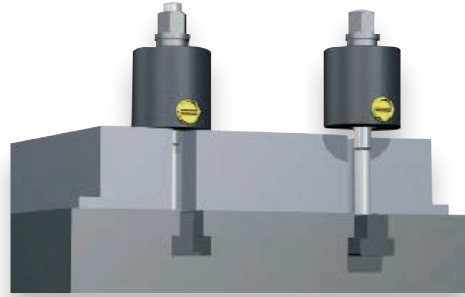

Removable clamps BTSA (040-02*) / BTSC (040-07*)

Standardisation of tools

Is the key to efficient clamping, especially when automation is desired. But even without standardisation, SERAPID clamps will still improve efficiency. For all dies in use, the following parameters should be the same:

- dimensions of die plates
- clamping stroke
- clamping positions

This basic data is necessary to select the right type of clamp:

- press tonnage and opening force in Newton [N]
- weight of dies in kg
- press stroke in cost / minute
- die change frequency in nombre /day
- space available for clamps on bolster and ram (dimension)

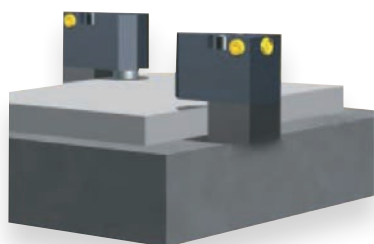

C-clamp PSH (050-03*)

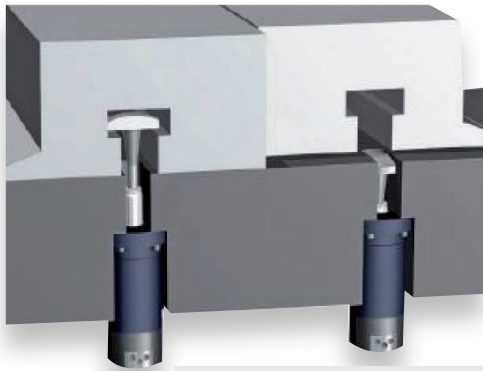

Swing sink clamp ROTO-ESCAM (090-02*)

Selecting clamps

■ Clamping position

Use on bolster or ram, at the sides of the die or on its front and rear.

■ Sensor-control

Some of our clamps can be equipped with inductive sensors to ensure proper positioning.

■ Retractable clamping anchor

The die-holding parts of the clamp are retracted when the clamp is opened.

■ Embedded clamps

When it is unlocked, the clamp disappears in the press table or in a T-slot. Suitable for dies that cover the entire surface of the bolster or ram or when a removable press table has to be re-used.

These clamps require that the clamping points are fully standardised and that the tools are equipped with appropriate holes or T-slots.

■ Roller-bar clamp

Embedded twin bars, equipped with rollers on the die's side for precise positioning of the tool.

■ Clamping height

The distance to be spanned by the tightened clamp.

■ Automation capability

Most of our clamps are suitable for fully automatic clamping.

■ Clamping power

Our clamps can be driven in three different ways:

Double-action, hydraulic tightening and releasing

This type not only allows for optimum efficiency, but, depending on the installation, also for active safety functions or best use of available machine space.

Single-action, hydraulic tightening with mechanical spring washers "Belleville" release,

A cost-effective solution, which can be used for full automation in certain applications. The pressure can be controlled and monitored to allow additional safety mechanisms.

Mechanical: mechanical spring washers "Belleville" tightening, hydraulic releasing

A simple and reliable solution. Clamps must be positioned manually.

■ Hydraulic supply

BSPP or UNF according products.

For an overview of our hydraulic power packs, see p. 20-21.

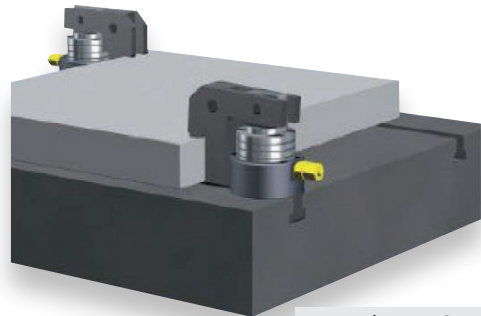

Lever clamp BCM (060-01*)

For further information on each of our clamp types, visit our website www.serapid.com. To find or request data-sheets and technical drawings, use the code specified with each product, for instance:

→ BTSC (040-07*)

2 CLAMPS

Fixed clamp...

Only fixed clamps allow full automation with no further aid, but they require full standardisation of the die interface.

... or removable ?

Removable clamps are more adaptable, but prevent the automation of the entire QDX process.

Fixed clamps

The clamp is integrated permanently into the bolster or ram, at the clamping position. When opened it

clears the die's transfer path by retracting the holding part or- with roller-bar clamps- by lifting the die. These movements are driven hydraulically.

Fixed clamps	Position:				Features:						Power:		
	bolster	ram	front/rear	lateral	sensors	escaping	embedded	roller-bar	automation	clamping stroke (mm)	double-action	single-action	mechanical
Escaping arc clamp (080-03*)	■	■		■	■	■			■	0-2	■		
Roller bar clamp (embedded) LSGH (070-02*)	■		■				■	■	■	0-8	■		
Tilting rod clamp TB90 (090-01*)	■	■	■		■	■	■		■	0-7	■		
Ledge clamp PHL (050-04*)	■	□		■					■	0-7		■	
Roller bar clamp (outside) LSHP (070-03*)	■		■				■	■	■	0-7	■		
Swing sink clamp ROTO-ESCAM (090-02*)	■	■	■	■	■	■	■		■	on request	■		
Horizontal wedge clamp TBH (080-01*) / Inclined wedge clamp TBHI (080-02*)	■	■		■	■	■			■	0-2	■		
C-Clamp without leg PSH (050-03*)	■	□		■					■	0-12		■	

■ standard □ option



080-03*



070-02*



090-01*



050-04*



070-03*



090-02*



080-01*

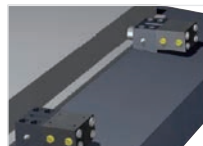

080-02*



050-03*

Removable clamps

For die change the clamps must be removed and re-inserted manually. This solution is cost-saving

and flexible, but more labour-intensive.

Removable clamps	Position:				Features:						Power:		
	bolster	ram	front/rear	lateral	sensors	escaping	embedded	roller-bar	automation	clamping stroke (mm)	double-action	single-action	mechanical
C-Clamp PSH (050-03*)	■	■	■	■						0-12		■	
Rod clamps BTSA (040-02*) / BTSB (040-03*) / BTSC (040-07*)	■	■	■	□						0-15		■	
Rod clamp BTM (040-01*)	■	■	■	□						0-2			■
Bar clamp LSH (070-01*)	■	□	■				■	■	■	0-3		■	
Lever clamp BCM (060-01*)	■	■	□	■						0-2			■
Lever clamp BLH (060-02*)	■	□		■	■				■	0-2		■	

■ standard □ option



050-03*



040-07*

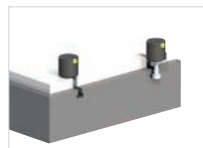

040-01*

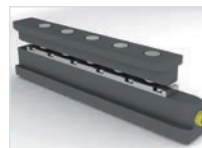

070-01*

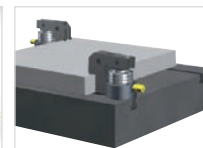

060-01*



060-02*

2 Fixed clamps

- Various dimensions and capacities
- Custom manufacturing
- Standard working temperature up to 70 °C, 160 °C with Viton seals

Escaping arc clamp TBHS

Shock resistant clamp with a curved motion
20-630 kN | 8 models

- Escaping arc shape, clamping wedge moving in and out on a curving path
- Horizontal clamping surface
- Vertical clamping force, without a radial load (force component)
- Shock resistant
- Mechanical locking holds the die without pressure drops

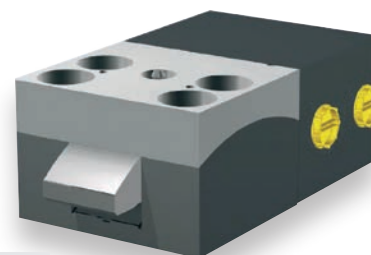

TBHS (080-03*)

Wedge clamp TBH

Clamping on the edge of the die with a 20° slope
25-100 kN | 3 models

- Clamping surface sloped at 20°
- Horizontal action clamp
- Hydraulic clamping and release

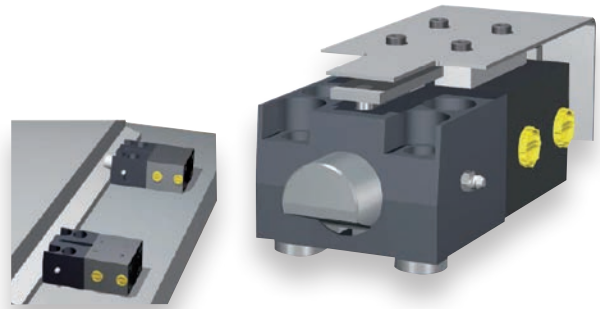

TBH (080-01*)

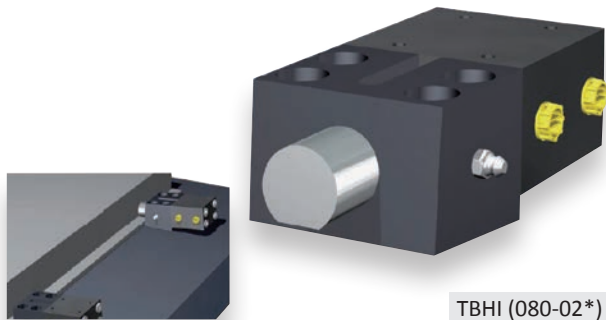

TBHI (080-02*)

Wedge clamp TBHI

Clamping on tool edge with wedge movement
15-100 kN | 4 models

- Horizontal clamping surface
- Wedge clamp
- Hydraulic clamping and release

Roller bar clamp LSHP with outside rollers (GP)

Double T slot with rolling track
For GP45 load bearing rollers
60-100 kN | 2 models

- Fixed in the bolster T slot, the bar clamps the die using its T slots
- Hydraulic clamping and lifting
- Clamps large tools that completely cover the press table
- Several bars can be combined to cover the entire bolster length
- Movement of the die on the bar clamps using the GP45 load bearing rollers (070-06*)
- Different models available according to DIN 650 T28 (070-04*) with GP30 load bearing roller (070-05*)

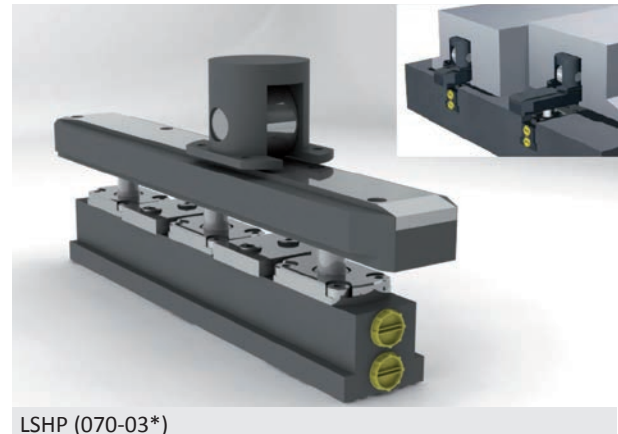

LSHP (070-03*)

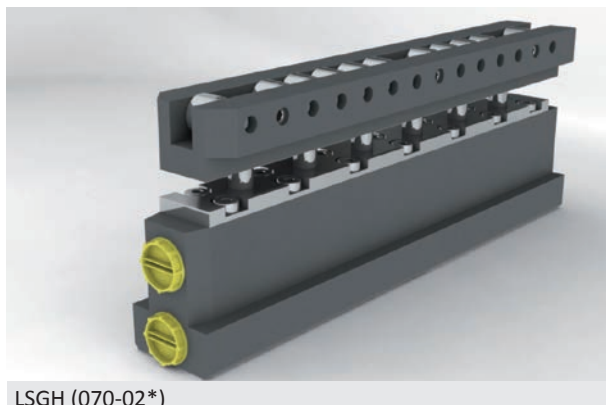

LSGH (070-02*)

Roller bar clamp LSGH T-slot with embedded rollers

Double T slot with rolling track
25-140 kN | 4 models

- Fixed in the bolster T-slot, the bar clamps the die using its T-slots
- Rolling track on the upper part
- Hydraulic clamping and lifting
- Several bars can be combined to cover the entire bolster length

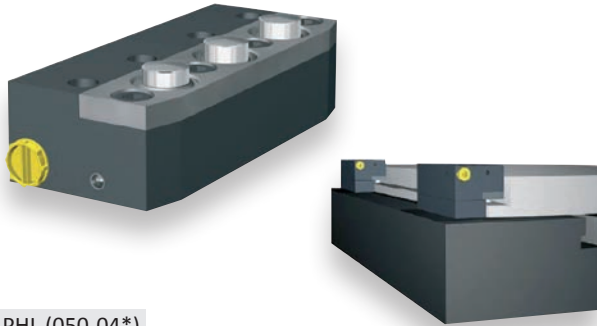

PHL (050-04*)

Ledge clamp PHL

Side clamp, easy to install
85-250 kN | 3 models

- Static side clamp
- Several clamps can be combined in lines
- Variable clamping height depending on the blocks used
- Location for standardised dies on the bolster
- Location on the ram possible when the ram of press can be electronically controlled

Tilting rod clamp TB90

Fixed clamp with 90° tilting rod
60-100 kN | 2 models

- Fully built into the bolster or ram
- The rod tilts 90° after opening and is then in a horizontal position
- 2 inductive sensors for position control
- Working temperature of up to 70 °C

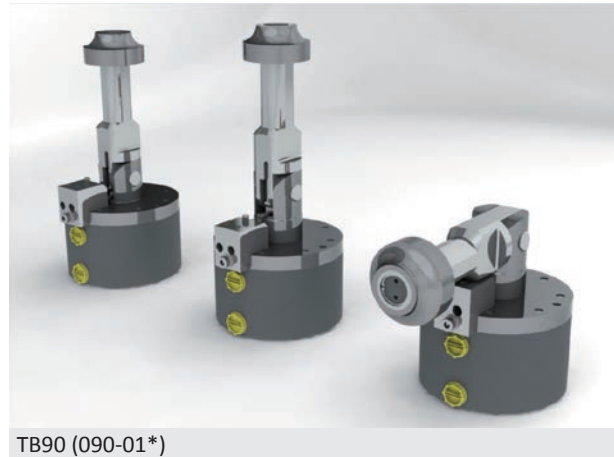

TB90 (090-01*)

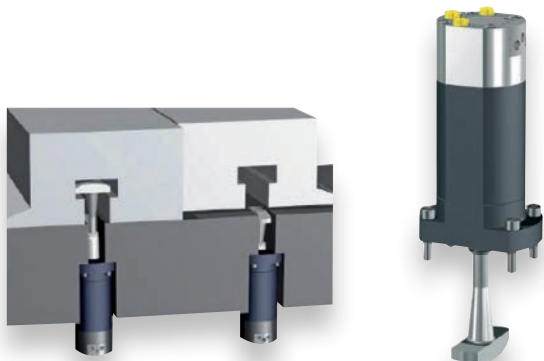

ROTO (090-02*)

Swing sink clamp ROTO-ESCAM

Clamping / unclamping and rotation are done in separate sequences to avoid any collision or blockage
50-200 kN | 4 models

- Fully automated with descending and rotating pulling
- Rotating clamping element for DIN 650 T-slots or specific slots
- Fully enters and exits the ram T-slot
- Position check using inductive sensors
- All movements are controlled by a PLC module
- Stroke on request
- Working temperature of up to 70 °C

2 Removable clamps

- Various dimensions and capacities
- Custom manufacturing, adapted to your standard DIN 650 or special slots
- Standard working temperature up to 70 °C, 160 °C with Viton seals

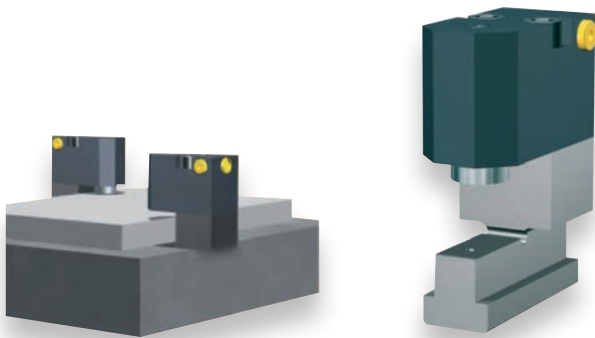

PSH (050-03*)

C-Clamp PSH

Straight edge clamping
20-100 kN | 4 models

- Manually inserted into the T slot or static
- Hydraulic clamping, mechanical spring washers “Belleville” release
- Adapted to press bolsters and rams
- Easily adaptable clamping height

Rod clamps BTSA / BTSB / BTSC

With variable clamping height (BTSC)
or fixed (BTSA, BTSB)

60-150 kN | 13 models

- Replaces traditional nut and bolt clamping
- Manually inserted into the T-slot or static
- Rod adjustable by ± 10 mm depending on the die height (BTSA)
- Fixed clamping height using a fixed height rod, on request (BTSB)
- Clamping height is adjustable depending on the die, interval of 5 to 130 mm (BTSC)
- Compact and particularly cost effective shape

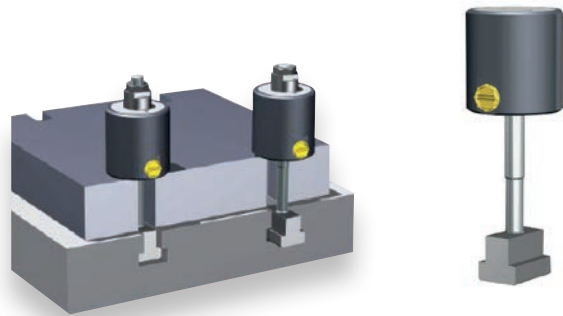

BTSA (040-02*) - BTSB (040-03*) - BTSC (040-07*)

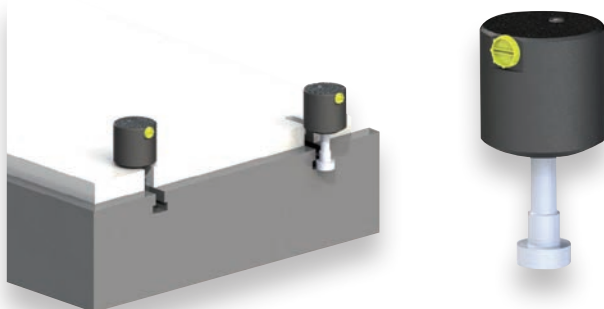

BTM (040-01*)

Rod clamp BTM

Hydraulically released mechanical clamp
20-60 kN | 3 models

- Manually inserted into the T slot or static
- Mechanical clamping, using spring washers “Belleville” and hydraulic release
- Clamping height set by the length of the clamp rod size according to your requirements

Bar clamp LSH

Double T slot
30-156 kN | 6 models

- Manually inserted into the T-slot of the ram and of the tool
- Can be combined with LSGH and LSHP type clamps on bolster only
- Hydraulic clamping, mechanical opening using the spring force
- Clamping of dies covering the entire bolster

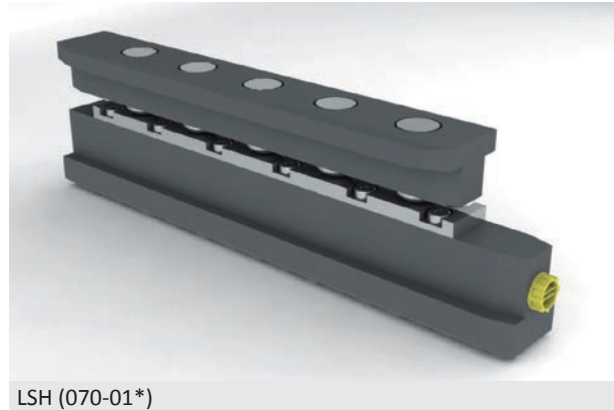

LSH (070-01*)

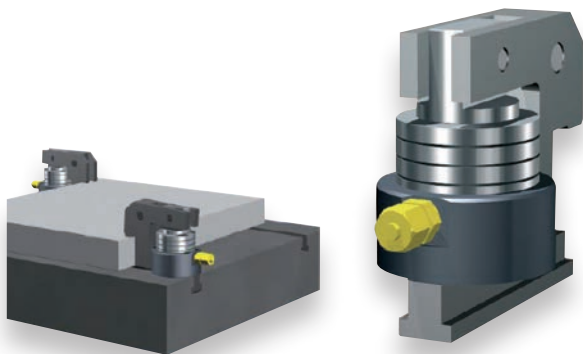

BCM (060-01*)

Lever clamp BCM

Mechanical clamping with hydraulic release
20-60 kN | 3 models

- Mechanical clamping using spring washers “Belleville” force, hydraulic release
- Manually installed in the T slot
- Clamping height can reach a maximum of 80 mm

Lever clamp BLH

Hydraulic clamping, mechanical release
40-60 kN | 2 models

- Hydraulic lever clamp
- Mechanical release using 2 springs
- Manually inserted into the T slot or static
- Particularly narrow clamp

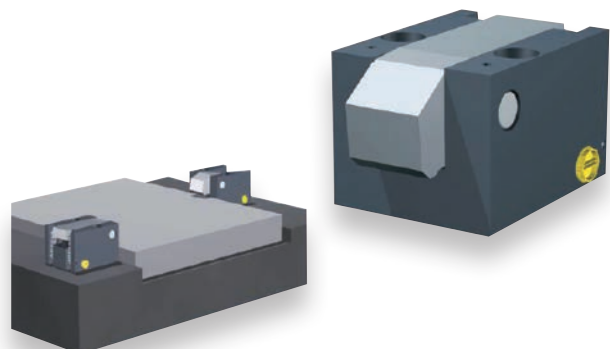

BLH (060-02*)

3 HYDRAULIC

Depending on the size and the degree of automation of your QDX system, you may choose between two options, pump or power pack, for driving hydraulic units.

Hydraulic rollers and hydraulically opened clamps

They require only one hydraulic circuit, which is used occasionally. Thus, for a limited number of bars and/or clamps, the easiest and most cost-effective solution is a manual pump. We offer a ready-to-install pump kit. For more hydraulic units, and particularly for our LGGH heavy-duty roller bar, we recommend an air-driven pump.

KA (HK) electric power pack

- Compact unit, consisting of a hydraulic pump and a motor
- Radial piston pump
- Effective volume: from 1,8 to 5,4 l
- Engine power: 1 kW in 230 or 400 V (2,2 kW)
- Tri-phased 50 Hz IP 54
- Factory pre-set operating pressure until 400 bars 1, 2 or 3 flow rates from 1 to 13 l/mn
- Closed aluminum casing allows sufficient cooling for continuous operation
- Large range of pressure adjustments until 400 bars
- With terminal box for remote control or integrated electrical control unit

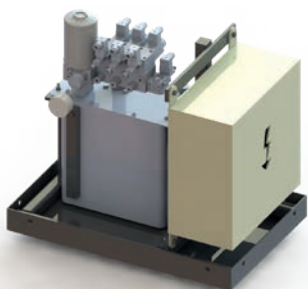

Air driven hydraulic pump unit LP (110-03*)

Clamps with hydraulic closure

It requires control of output power for closing, and therefore a regulated power pack and a directional seated valve bank.

Our clamping power packs work in watch mode. Once the working pressure has been obtained, the power pack stops output and restarts only to compensate for pressure drops. A pressure-monitoring switch has to be integrated in each clamping circuit, to stop the press, if any of the clamping devices receive less than 80 % of the pressure setting.

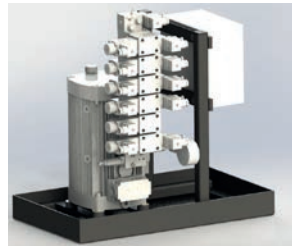

Compact electric unit with connection terminal box (110-04*)

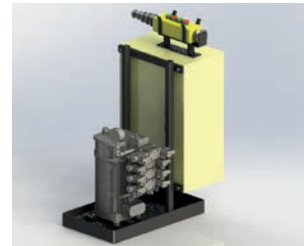

Hydraulic power unit with electronic control cabinet (110-05*)

LP air-driven hydraulics power pack

- Effective volume: 4 l
- Factory pre-set operating pressure until 400 bars
- Flow rate when not under load: 2 l/mn
Under load: 1 l/mn at 400 bars
- Air supply: 6 bars
- Controlled by air-to-oil pressure ratio
- Pressure monitoring with compensation for pressure drops

Manual pump kit

- Two speeds
- Effective volume: 327 cm³
- Factory pre-set operating pressure 100, 200 or 400 bars according to the product
- Includes connectors and piping
- Further accessories



Hand pump (110-01*)

Valve bank

- Modular valve bank with ball waterproof valves
- Compact unit including pressure limiter and switch
- One pressure-monitoring switch per clamping circuit
- Valves are in resting position when circuits are in clamping, pressure-on state-safe clamping even if power fails

110-06* valve bank

To avoid unwanted counter pressure, a power pack without return filter should be used. If a return filter has to be used, a filling indicator must be present. Various accessories and complete hydraulics installations can be found under:

110-07* hydraulics accessories

Foot-operated hydro-pneumatic pump

- Effective volume: 589 cm³
- Factory pre-set operating pressure 100, 200 ou 400 bars according to the product
- Flow rate when not under load: 0,65 l/mn
Under load: 0,13 l/mn
- Installation kits including fittings and hoses as required
- Further accessories

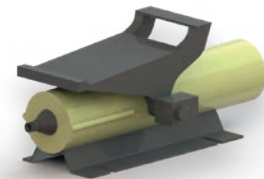

Foot-operated hydro-pneumatic pump (110-02*)

External hydraulic sources may be supplied by the user under the following conditions:

- oil type HLP 32 or 46 Cst is used
- output is regulated and protected by a pressure limiter
- flow rates from 0.8 to 4 l/min available
- the valve bank has to be a ball-type design with a non-return valve at the bottom of the column

Examples of configuration of hydraulic circuits

Example 1 shows four diagonal circuits for tightening and releasing clamps on the ram, and two circuits for tightening and releasing clamps on the bolster. One circuit supplies up to 100 bar for rolling devices.

Schema 1

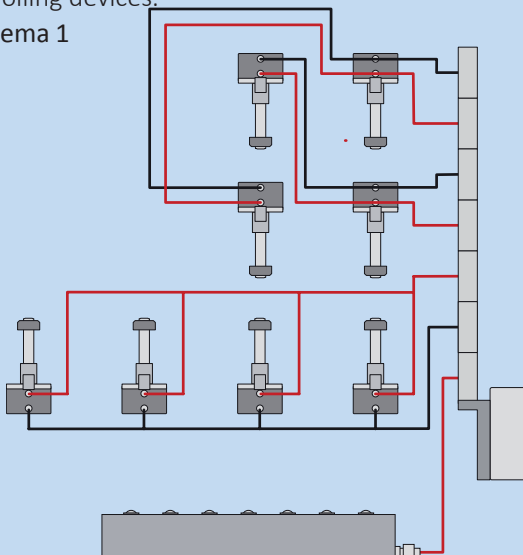

Example 2 shows two diagonal circuits for tightening and one circuit for releasing clamps on the ram, and two circuits for tightening and releasing clamps on the bolster (LGGH).

Schema 2

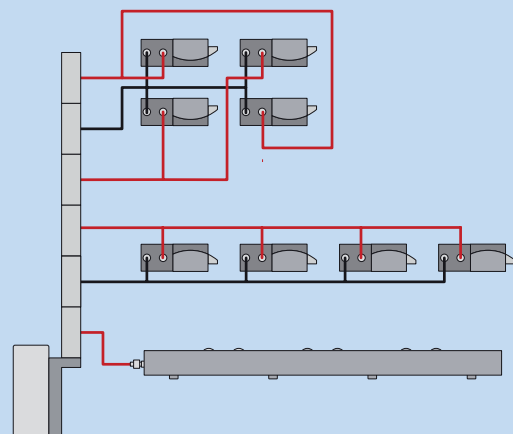

RANGE OF COMPLEMENTARY SOLUTIONS FOR DIE POSITIONING AND TRANSPORT

For a complete quick die change solution, SERAPID has also designed a large range of tool transfer equipment ranging from fork lift trucks to automated rail mounted carts. They reduce transit and handling times between the storage area and the production area.

SERAPID standard solutions include:

- **the PPS series - Push Pull System**- push / pull- fixed or removable mounted on presses
- **the TPCH – TPCH series - Horizontal Loading Positioning Table**- fork lift truck accessories, adding a mechanised die loading system to any existing fork lift truck
- **the GPO series - Die Carrier and Stacker**- pedestrian controlled stacker or driver controlled truck

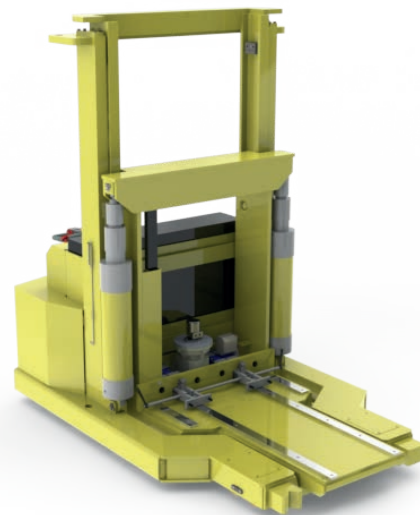

For further information,

ask for our specific brochure on our website www.serapid.com or to your SERAPID contact.

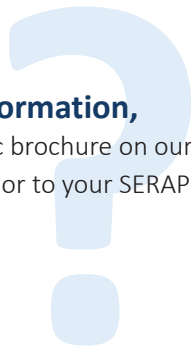

Examples of applications:



Driver-operated truck with dual load platforms for loading and transporting tools between presses and storage areas



Push-pull system (PPS) for optimal positioning of the tool in the integrated press on the truck by the customer



Basket carrier stacker for loading and unloading thermal ovens

LIFTING AND PUSH-PULL SOLUTIONS

With 45 years of experience in handling equipment, SERAPID has supplied systems for many manufacturers and subcontractors in the industry. Our expertise enables us to provide reliable and bold solutions to meet the most complex requirements for elevation or load transfer in specific and demanding environments. SERAPID Rigid Chain Technology, (RCT) is a true alternative to traditional mechanical and hydraulic solutions, and allows us to offer the most compact and robust equipment.

Telescopic, easy to install, low maintenance and eco-friendly, RCT is based on a very simple mechanical concept, one that provides undeniable efficiency and durability.

Our specific systems can be integrated with SMED solutions (Single Minute Exchange of Die)/ Lean Manufacturing.



Lifting actuators

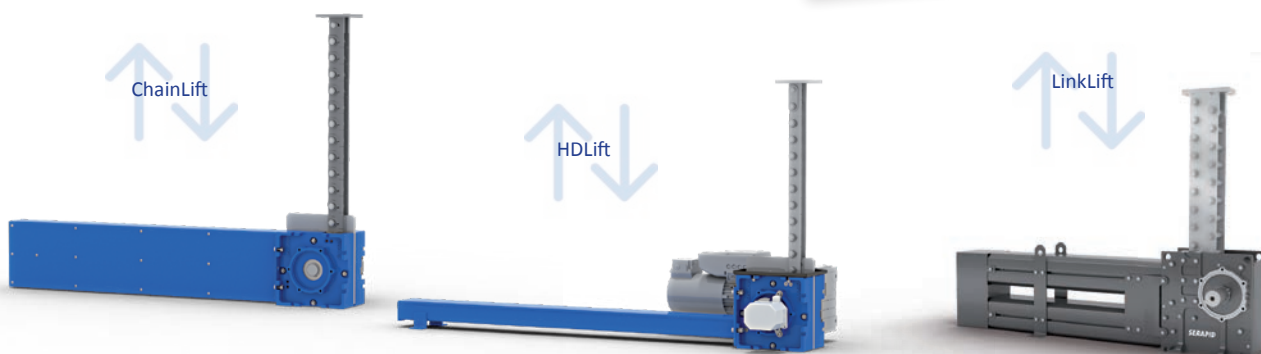

Horizontal actuators

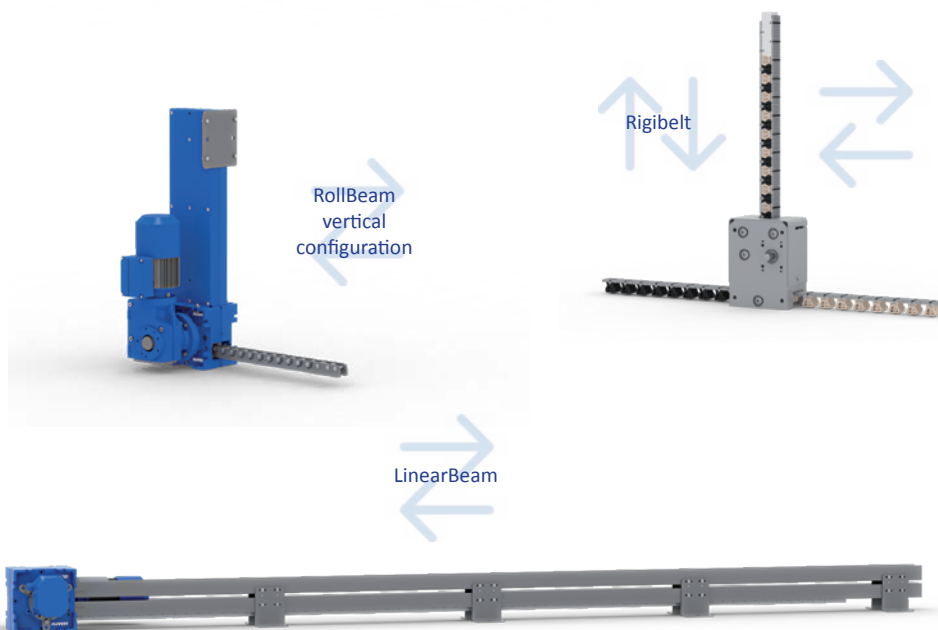

They trust us :



SERAPID France - Head Office

ZI Louis Delaporte, Zone Bleue, Voie F
F-76370 Rouxmesnil-Bouteilles | France
+33 (0)2 32 06 35 60
info-fr@serapid.com

SERAPID Ltd

Elm Farm Park, Great Green, Thurston,
Bury St Edmunds | IP31 3SH England
+44 (0)1359 233335
info-uk@serapid.com

SERAPID Deutschland GmbH

Wilhelm-Frank-Straße 30
D-97980 Bad Mergentheim | Germany
+49 (0)7931 9647-0
info-de@serapid.com

SERAPID USA INC.

34100 Mound Road
Sterling Heights MI 48310 | USA
+1 586 274 0774
info-us@serapid.com

SERAPID Singapore Pte Ltd

1 George Street #10-01
Singapore 049145 | Singapore
+65 9119 5890
info-sg@serapid.com

SERAPID Italy Office | +39 01 18 00 35 44 | info-it@serapid.com
SERAPID Mexico Office / LATAM | +52 1 442 4 900 701 | info-mx@serapid.com

SERAPID China Office | +86 185 1215 0303 | info-cn@serapid.com
SERAPID Brazil Office | +55 11 9 73 85 78 37 | info-br@serapid.com

SERAPID
RIGID CHAIN TECHNOLOGY
www.serapid.com